

NORMALLY OPEN (STANDARD)

SEE REVERSE SIDE FOR CONFIGURATION OPTIONS

ITEM NO.	DESCRIPTION	PART NUMBER	QTY.	
1	BODY, 427, CAST IRON	1074446	1	
		1083918		
2	SEAT, 427, MACHINING	BRASS	1074505	1
3	NUT, HEX, 5/16"-24	SS	1263853	2
4	PLATE, DISC	(303 SS)	1074495	1
5	O-RING, ORV-233	FKM	1071826	1
6	DISC, 427	HYCAR	1074490	1
		TELFON	1074491	1
7	DISC HOLDER, ALUM/BRONZE		1074483	1
8	O-RING, -011	FKM	1071786	2
9	O-RING, -237	FKM	1071828	1
10	SHAFT GUIDE, MACHINING		1074479	1
11	LOCKWASHER, 5/16"		1073594	2
12	CAP, 427, MACHINING	CAST IRON	1074454	1
13	SCREW, 3/8-16 X 1 1/2", HX HD	PLATED STEEL	1072405	6
14	DIAPHRAGM SERIES 427,	BUNA-N	1074475	1
		FKM	1074477	1
15	HEX NUT, 3/8-16	PLATED STEEL	1071658	6
16	O-RING, -114	ALFAS	1071662	2
17	SHAFT, 427, NO		1074496	1
18	SPACER, BRASS		1074382	1
19	HEX HEAD CAP SCREW, 3/8-16 X 1.00	STAINLESS STEEL	19768	2
20	PLATE, UPPER DIAPHRAGM		1074472	1
21	DIAPH PLT, 427,LWR, MACH	SS	1074473	1

ASSEMBLY TOOLS	
DESCRIPTION	PART NO.
FOR INSTALLATION & REMOVAL OF SHAFT GUIDE (ITEM #10) (NOT SHOWN)	1-3/16" HEX SOCKET

REPAIR PARTS KITS		
DESCRIPTION	PART NO.	
DIAPHRAGM & SEALS KIT CONSISTS OF ITEM NO'S 3(2),5,6,8(2),9,14,16(2)	1070110 (AV7-RA)	1070516(AV7-RAHT)
	INCLUDES DISC 1074490 (427-JH), DIAPHRAGM 1074475 (427-FB)	INCLUDES DISC 1074491 (427-JT), DIAPHRAGM 1074477 (427-FV)
INT. PARTS KIT (NORM. OPEN) CONSISTS OF STANDARD ITEM NO'S 4,7,10,11,17,18,20,21	1070517 (AV7-RF)	
SEAT (ITEM NO. 2)	1074505	

THIRD ANGLE PROJECTION

DO NOT SCALE DRAWING.
DIMS. ARE IN INCHES (mm)

INTERPRET DIMS AND TOLERANCES PER ASME Y14.5M-2009
UNLESS OTHERWISE SPECIFIED:

TOLERANCES:
ANGLES: ± 1°
1 PLACE .X: ± .015 [0.38]
2 PLACE .XX: ± .01 [0.3]
3 PLACE .XXX: ± .005 [0.13]

TITLE
**CATALOG SHEET, AV7
DIAPHRAGM VALVE STANDARD MODEL**

SIZE **C** DWG NO. **BR1077639** REV **K**

SCALE 1:4 SHEET 1 OF 2

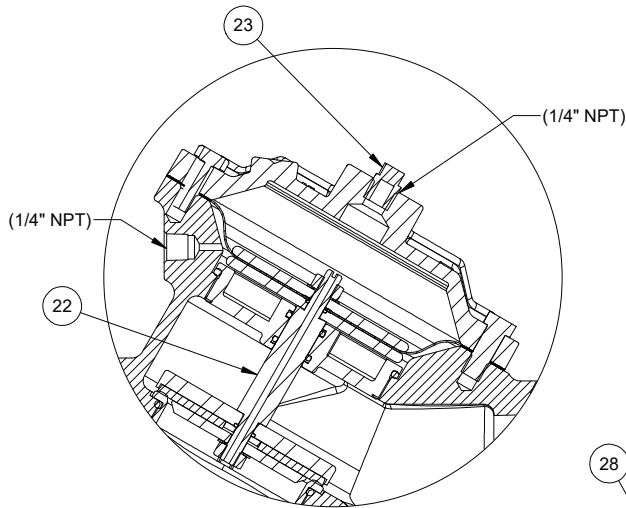

1269740 (VAVJ-0030-90000) (THREADED)
1242257 (VAVJ-3030-90000) (FLANGED)

NORMALLY CLOSED

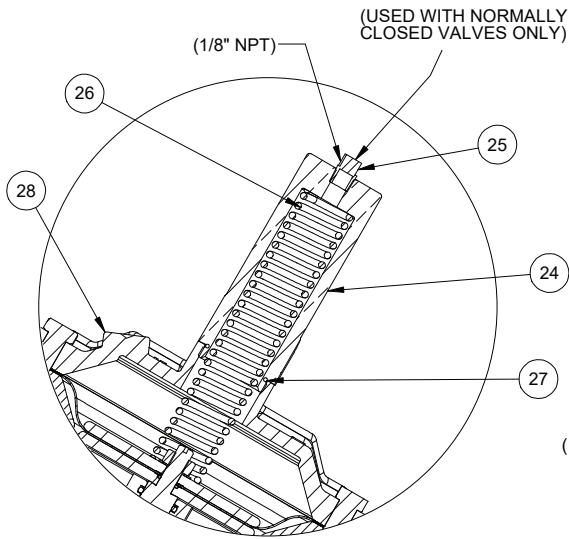

3018900 (VAVJ-0002-90000) (THREADED)
1080797 (VAVJ-3002-90000) (FLANGED)

SPRING ASSIST CLOSED

SEE REVERSE SIDE FOR
STANDARD NORMALLY OPEN MODEL

ITEM NO.	DESCRIPTION	PART NUMBER	QTY.	
22	SHAFT, 427, NC	1074499	1	
23	MALE PIPE PLUG	PLATED STEEL	1071918	1

SPRING ASSIST CLOSED MODEL

ITEM NO.	DESCRIPTION	PART NUMBER	QTY.	
24	NUT, SPRING RETAINER	BRASS	1074431	1
25	MALE PIPE PLUGS (1/8" NPT)	BRASS	1071903	1
26	COMPRESSION SPRING		1074429	1
27	O-RING, 2-025	BUNA	1071677	1
28	CAP, 427, SPRING ASSIST	CAST IRON	1074460	1

SPRING ASSIST OPEN MODEL

ITEM NO.	DESCRIPTION	PART NUMBER	QTY.	
29	SPRING, COMPRESSION		1078692	1
30	WASHER, CENTERING	BRASS	1074436	1

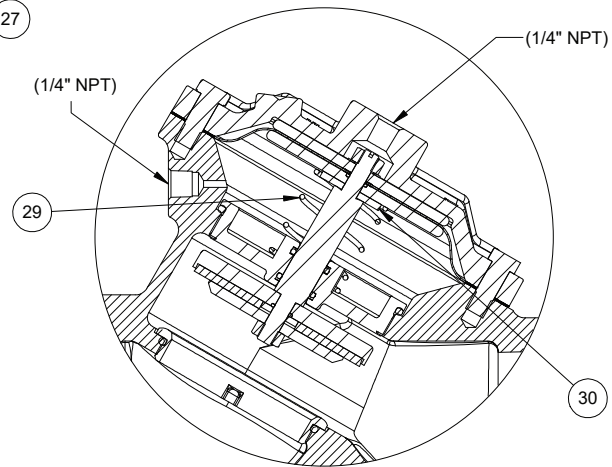



1072502 (VAVJ-0001-90000) (THREADED)
1072509 (VAVJ-3001-90000) (FLANGED)

SPRING ASSIST OPEN

REPAIR PARTS KITS	
DESCRIPTION	PART NO.
INT. PARTS KIT (NORM. CLOSED) CONSISTS OF STANDARD ITEM NO'S 4,7,10,11,18,20,21,23	BR1070518 (AV7-RG)
INT. PARTS KIT (SPRING ASSIST CLOSED) CONSISTS OF STANDARD ITEM NO'S 26,27	BR1070513 (AVG-SC)
INT. PARTS KIT (SPRING ASSIST OPEN) CONSISTS OF STANDARD ITEM NO'S 29, 30	BR1070520 (AV7-SO)

CONVERSION KITS	
DESCRIPTION	PART NO.
CONVERSION KIT (SPRING ASSIST CLOSED) CONSISTS OF STANDARD ITEM NO'S 24 THRU 28	BR1070519 (AV-SCC)
CONVERSION KIT (SPRING ASSIST OPEN) CONSISTS OF STANDARD ITEM NO'S 29, 30	BR1070520 (AV7-SO)

THIRD ANGLE PROJECTION  DO NOT SCALE DRAWING. DIMS. ARE IN INCHES [mm] INTERPRET DIMS AND TOLERANCES PER ASME Y14.5M -2009 UNLESS OTHERWISE SPECIFIED: TOLERANCES: ANGLES : ± 1° 1 PLACE .X: ± .015 [0.38] 2 PLACE .XX: ± .01 [0.3] 3 PLACE .XXX: ± .005 [0.13]		
	TITLE CATALOG SHEET, AV7 DIAPHRAGM VALVE STANDARD MODEL	
SIZE C	DWG NO. BR1077639	REV K
SCALE 4:5	SHEET 2 OF 2	